

Valves for Cryogenic Service

Type 01651 - Globe Valve "fire-safe"



Cryogenic-Globe and Globe/Check Valves, PN50 (DN100=PN40)

"Fire safe" type test approval acc. to EN ISO 10497

Stainless steel body and topwork, "live loaded" gland packing

"cleaned and degreased for oxygen service"

Part No. 01651.X.000*

Part No. 01651.X.500* Globe/Check Valve

*Butt weld connection for stainless steel pipes acc. to DIN EN ISO 1127 or ASTM A312

Part No. 01651.X.0004

Part No. 01651.X.5004 Globe/Check Valve

Socket weld connection for stainless steel pipes acc. to DIN EN ISO 1127 and ASTM A312

Available options - on request only:

· Welded stainless steel stubs acc. to DIN EN ISO 1127 or ASTM A312 - length FF + 150mm

· Valve with control disc (tapered design)



Applications:

Approved for air gases, vapours and cryogenic liquefied gases incl. LNG.

Working temperature: -196°C / -321°F (77K) up to +120°C / +248°F (393K)

Recommended working temperature: -60°C / -76°F (213K) up to +120°C / +248°F (393K)

Materials	DIN EN	ASTM
1 Body	1.4308	A 351 CF8
2 Valve seal	PTFE / Carbon filled (25%)	
3 Disc	1.4301	A 276 Grade 304
4 Bonnet gasket	Graphite	
5 Headpiece	1.4301	A 276 Grade 304
6 Bolts	1.4301/A2	A 194 B8
8 Stem	1.4301	A 276 Grade 304
9 Gland packing	Graphite / PTFE / MICA	
10 Gland nut	1.4305	A 276 Grade 303
11 Handwheel	Aluminium alloy	
12 Spring	1.4310	A 276 Grade 302
13 Bush	CW452K	B 103 Alloy A

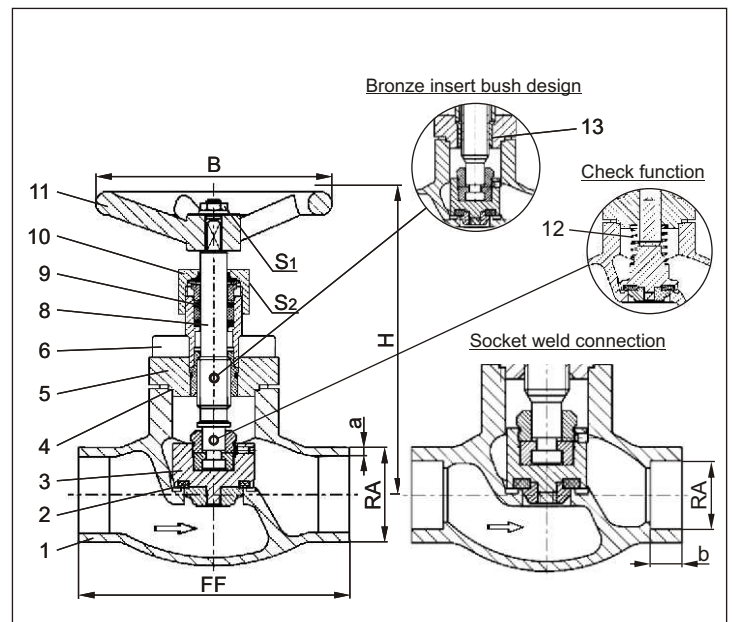

Standard marking acc. to Pressure Equipment Directive 97/23/EG (PED).



Marking acc. to Directive 99/36/EG (TPED) will only be carried out by written notice on purchase order.



Type 01651 – Standard design	Technical data												
	DN	10	15	15	20	25	32	40	40	50	65	80	100
Nominal size	.X.	1012	1517	1521	2026	2533	3238	4042	4048	5060	657x	8088	0114
Dimension code													
Face-to-face dimension	FF	70	85	85	100	115	115	130	130	155	205	245	280
Height	H	140	140	140	140	140	170	175	175	200	260	310	350
Outside pipe-Ø DIN EN ISO 1127	RA	12.0	17.2	21.3	26.9	33.7	38.0	42.4	48.3	60.3	76.1	88.9	114.3
Wall thickness pipe DIN EN ISO 1127	a	1.0	1.6	2.0	2.0	2.0	2.0	2.0	2.0	2.0	2.6	3.2	6.0
Outside pipe-Ø ASTM A312	RA	13.72	17.15	21.34	26.67	33.40	-	42.16	48.26	60.33	73.03	88.90	114.3
Wall thickness pipe ASTM A312	a	S10	S40	S10	S10	S10	-	S10	S10	S10	S40	S10	S40
Socket depth	b	6	10	10	13	13	-	13	13	16	16	16	20
Handwheel-Ø	B	80	100	100	100	100	125	125	125	125	200	250	315
Wrench size across flats	S ₁	10	10	10	10	10	13	13	13	13	13	13	13
Wrench size across flats	S ₂	30	30	30	30	30	36	36	36	36	36	36	41
Weight	ca. kg	1.0	1.25	1.3	1.7	2.0	2.8	4.2	4.2	6.7	10.7	16.0	23.0
Kvs – Value	m ³ /h	1.6	3.8	4.3	6.7	11.5	14.0	20.6	22.6	37.1	71.1	104.0	170.0
Cv – Value	gal /min	1.9	4.4	5.0	7.8	13.4	16.2	23.9	26.3	43.2	82.7	120.9	195.2

Dimensions in mm.